



TAI-SAW TECHNOLOGY CO., LTD.

No. 3, Industrial 2nd Rd., Ping-Chen Industrial District,
Taoyuan, 324, Taiwan, R.O.C.

TEL: 886-3-4690038 FAX: 886-3-4697532

E-mail: tstsales@mail.taisaw.com Web: www.taisaw.com

Product Specifications Approval Sheet

Product Description: SAW Filter 719 MHz SMD 2.0x1.6 mm

TST Part No.: TA1037A

Customer Part No.: _____

Customer signature required
Company: _____
Division: _____
Approved by : _____
Date: _____

Checked by: _____ David Chang 張閔智

Approved by: _____ Francis Chen 

Date: _____ 2009/07/02

1. Customer signed back is required before TST can proceed with sample build and receive orders.
2. Orders received without customer signed back will be regarded as agreement on the specifications.
3. Any specifications changes must be approved upon by both parties and a new revision of specifications shall be released to reflect the changes.



TAI-SAW TECHNOLOGY CO., LTD.

No. 3, Industrial 2nd Rd., Ping-Chen Industrial District,
Taoyuan, 324, Taiwan, R.O.C.

TEL: 886-3-4690038 FAX: 886-3-4697532

E-mail: tstsales@mail.taisaw.com Web: www.taisaw.com

SAW Filter 719 MHz

MODEL NO.:TA1037A

REV. NO.:1

A. MAXIMUM RATING:

1. Input Power Level: 10 dBm
2. DC Voltage : 3V
3. Operating Temperature: -30°C to +85°C
4. Storage Temperature: -40°C to +85°C

RoHS Compliant
Lead free
Lead-free soldering

B. ELECTRICAL CHARACTERISTICS:

Item	Unit	Min.	Type.	Max.	Note
Center Frequency Fc	MHz	-	719	-	-
Min. Insertion loss (716.5~721.5 MHz) IL	dB	-	2.7	3.2	-
Amplitude Ripple (716.5 ~ 721.5 MHz)	dB	-	0.7	2.2	-
Return Loss (716.5~721.5 MHz)	dB	5	8	-	-
Group Delay Ripple (716.5~721.5 MHz)	ns	-	42	95	-
Attenuation (Reference level from 0 dB)					
D.C ~ 690 MHz	dB	40	54	-	-
690 ~ 704 MHz	dB	35	47	-	-
704 ~ 710 MHz	dB	30	48	-	-
728 ~ 734 MHz	dB	25	29	-	-
734 ~ 750 MHz	dB	27	33	-	-
750 ~ 824 MHz	dB	37	53	-	-
824 ~ 960 MHz	dB	45	54	-	-
960 ~ 2500 MHz	dB	32	39	-	-
Temperature coefficient of frequency TCf		-36 ppm / °C			

C. MEASUREMENT CIRCUIT:

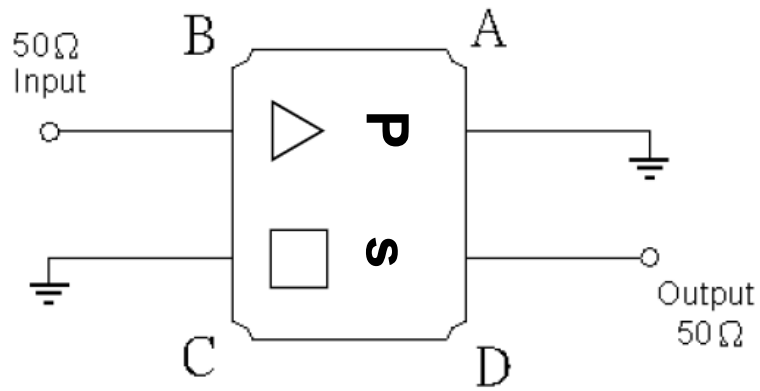

D. OUTLINE DRAWING:

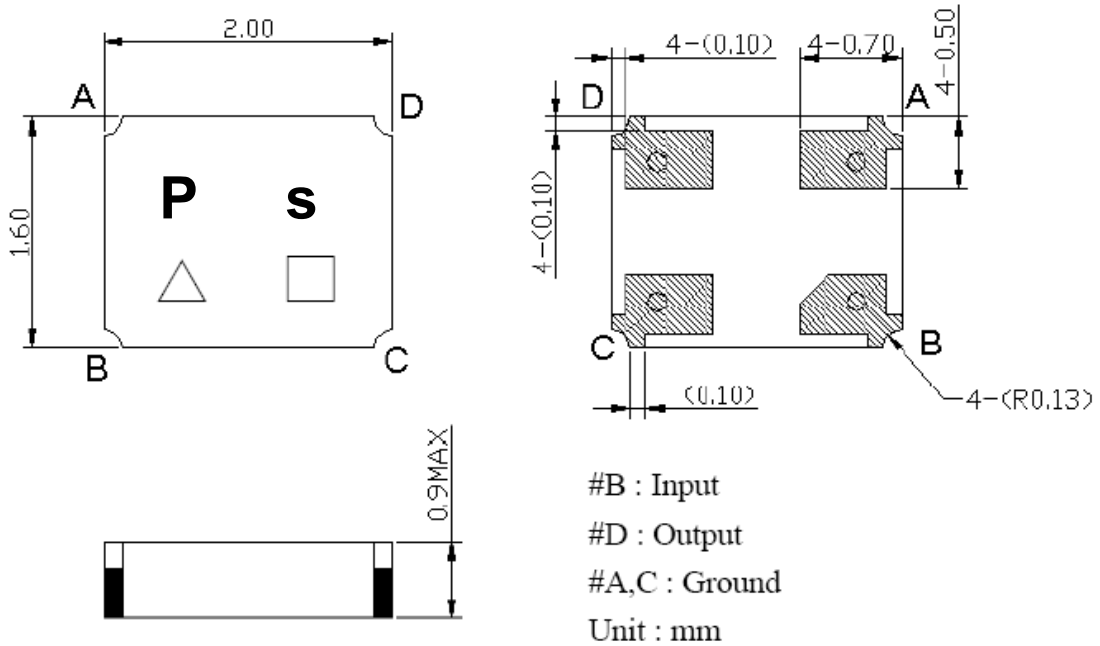

- △ : Year Code (2006->6, ..., 2009->9)
- : Date Code (Follow the table from planner each year)

E. Frequency Characteristics :

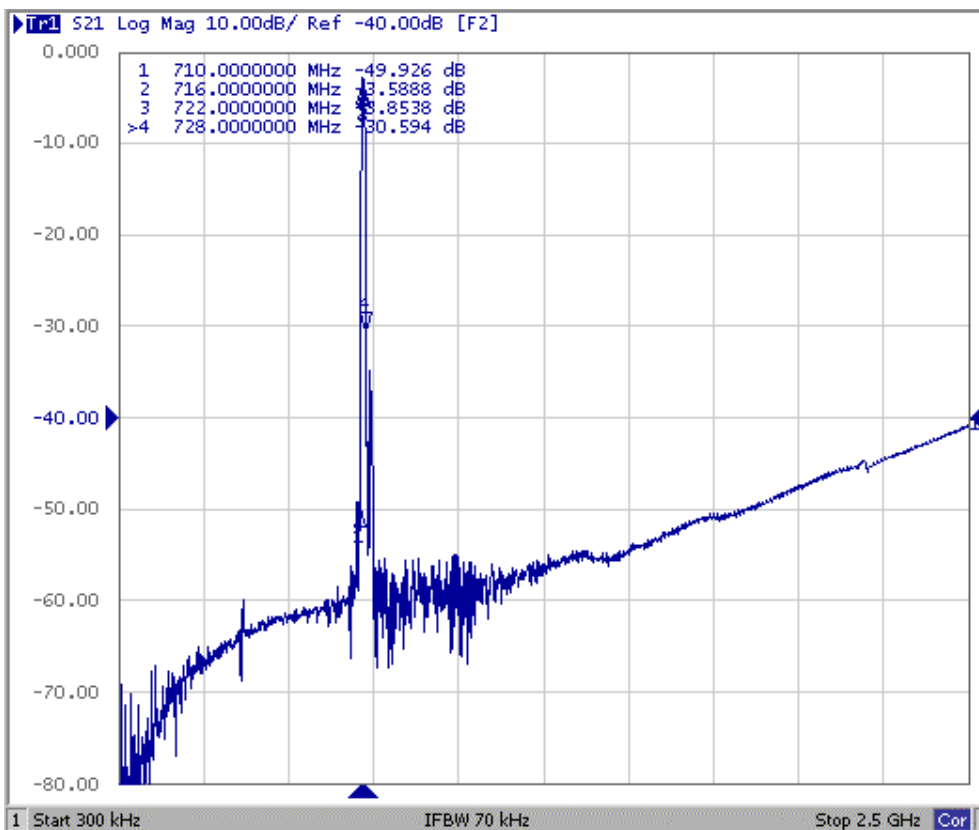
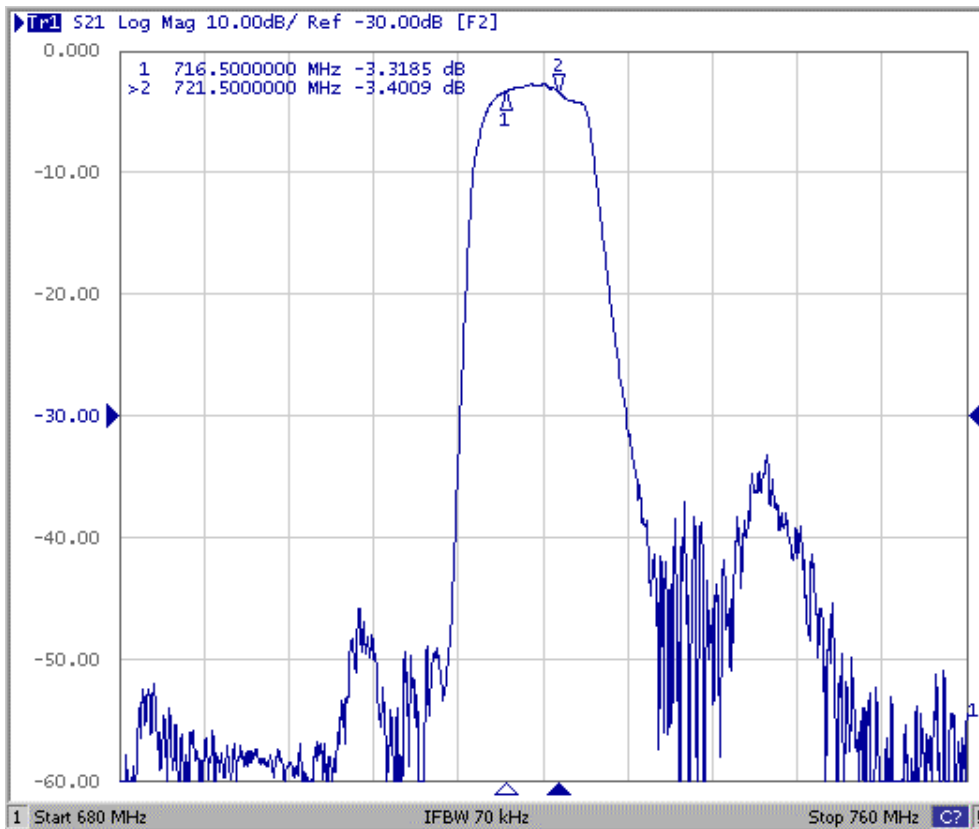

Reflection Functions :

S11

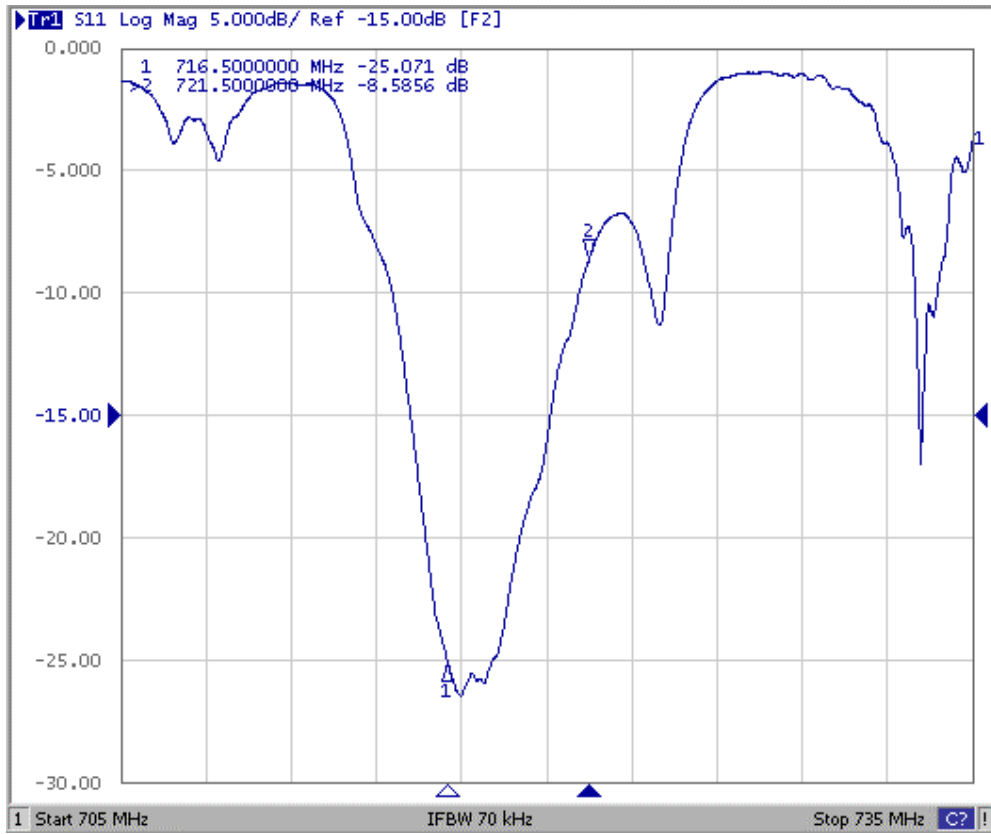

S22

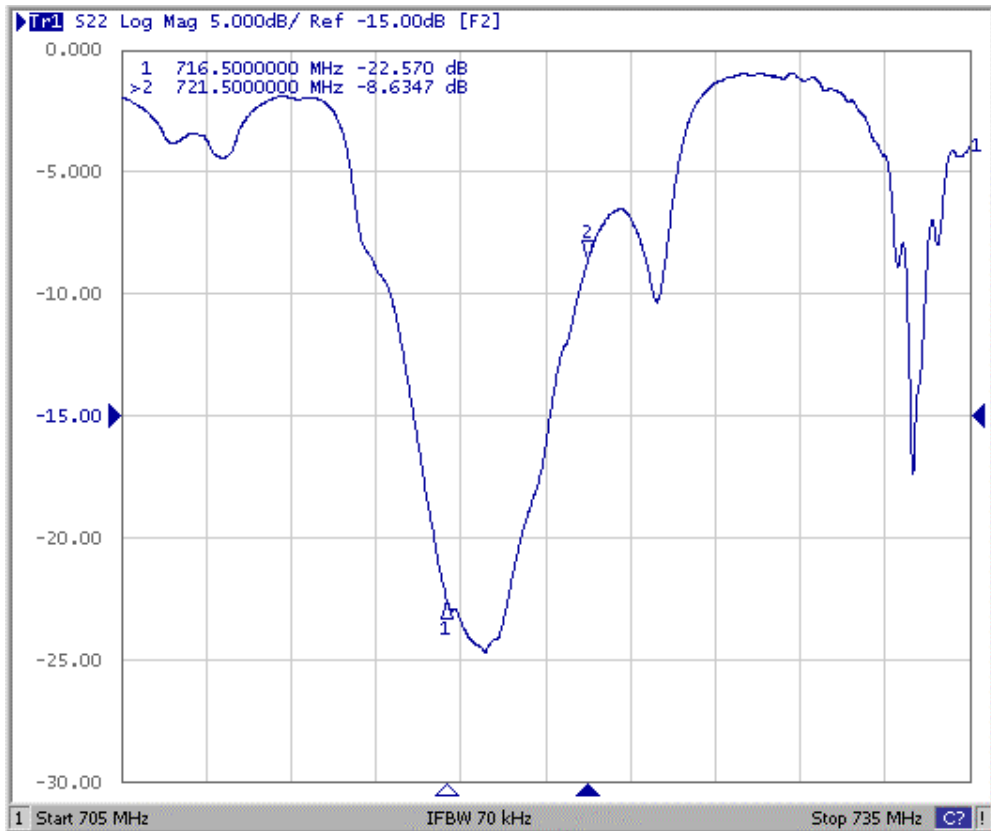

F. PACKING:

1. REEL DIMENSION

(Reel Count : 7"=1000 ; 13"=3000)

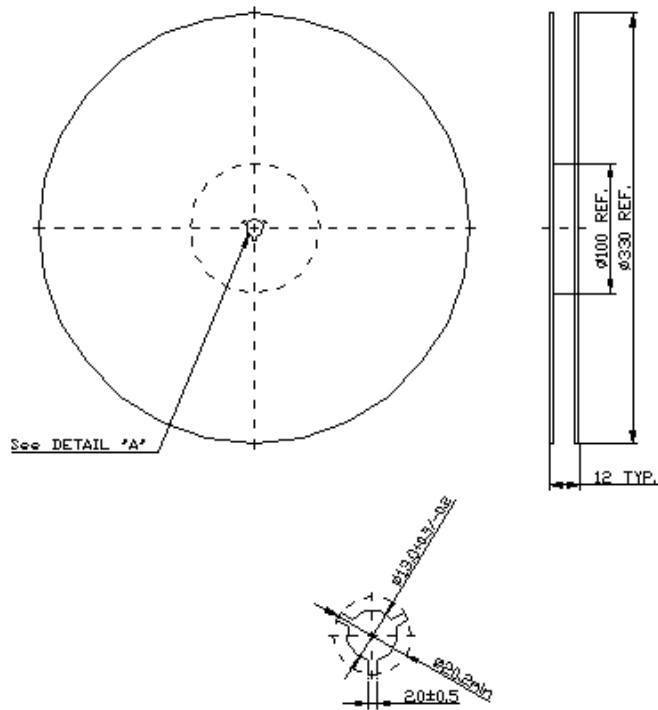

2.TAPE DIMENSION

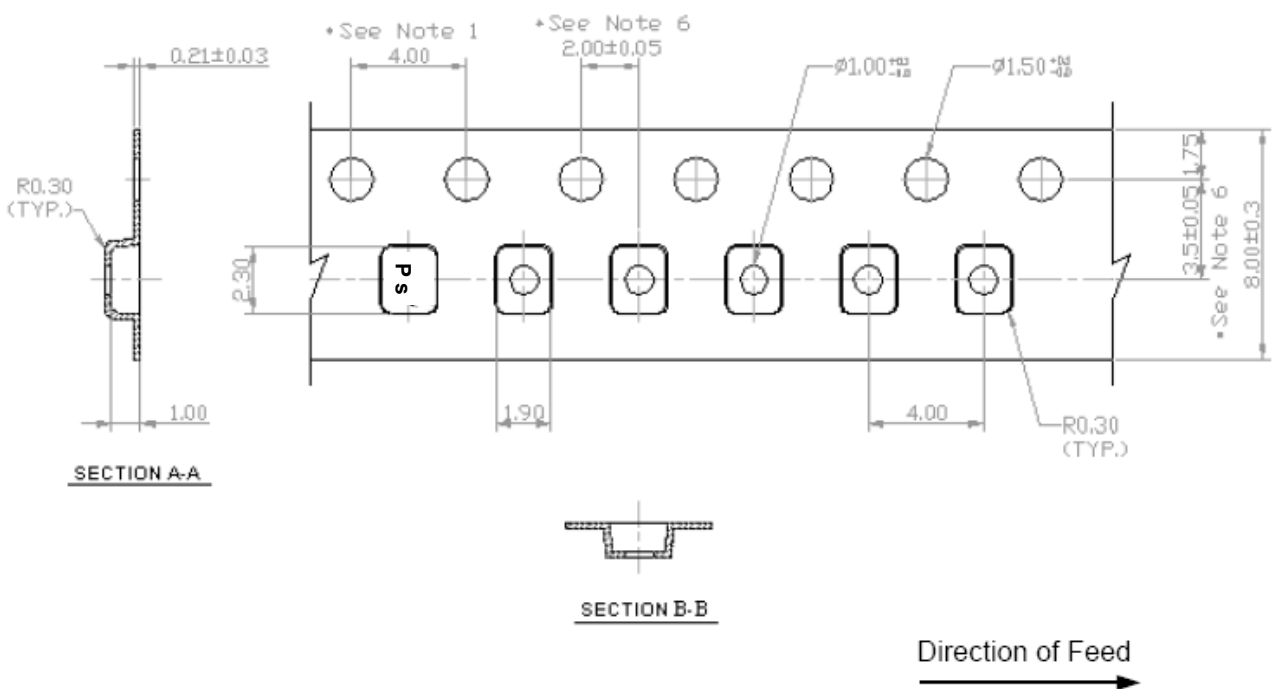

G. RECOMMENDED REFLOW PROFILE :

